

Published by:
Service Department Audio



BUSINESS CREATION UNIT AUDIO

SERVICE NEWSLETTER

General Information

This special edition contains instructions on CD-applications with playability problems (i.e. skipping tracks). The information shows how to check the playability of the set, how to clean the lens, and how to measure if some important drive parameters like jitter, laser current and offset values are (still) within the specification.

Background for this information are extensive analyses on replaced CD-drives. It has been found that a lot of replaced drives were not defective at all, respectively were replaced for the wrong reason. We are convinced that the procedures on the next pages will help to reduce the number of erroneously replaced drives drastically and request you to deploy the instructions to the workshops urgently.

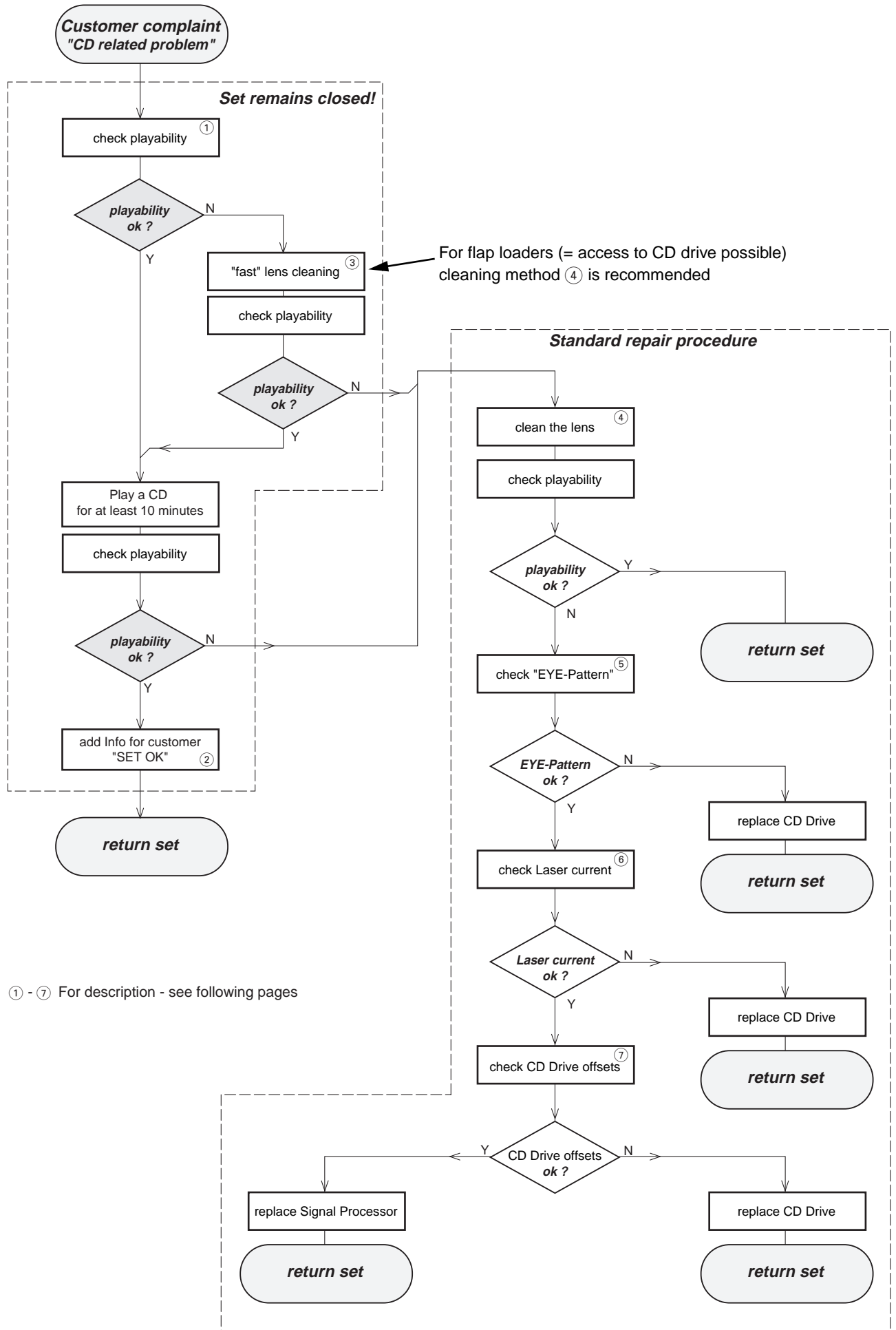

① - ⑦ For description - see following pages

①

PLAYABILITY CHECK

For sets which are compatible with **CD-RW** discs
use CD-RW Printed Audio Disc7104 099 96611
TR 3 (Fingerprint)
TR 8 (600µ Black dot) **maximum at 01:00**

- playback of these two tracks without audible disturbance
playing time for: Fingerprint ≥10seconds
Black dot from 00:50 to 01:10
- jump forward/backward (search) within a reasonable time

For all other sets
use CD-DA SBC 444A4822 397 30245
TR 14 (600µ Black dot) **maximum at 01:15**
TR 19 (Fingerprint)
TR 10 (1000µ wedge)

- playback of all these tracks without audible disturbance
playing time for: 1000µ wedge ≥10seconds
Fingerprint ≥10seconds
Black dot from 01:05 to 01:25
- jump forward/backward (search) within a reasonable time

②

CUSTOMER INFORMATION

It is proposed to add an addendum sheet to the set which informs the customer that the set has been checked carefully - but no fault was found.

The problem was obviously caused by a scratched, dirty or copy-protected CD. In case problems remain, the customer is requested to contact the workshop directly.

The lens cleaning (method ③) should be mentioned in the addendum sheet.

The final wording in national language as well as the printing is under responsibility of the Regional Service Organizations.

③

FAST LENS CLEANING (dry brush)

Use lens cleaning CD
SBC AC3009082 100 00043

Insert the lens cleaning CD, press PLAY and follow the voice guide's instructions on the CD.

④

LIQUID LENS CLEANING

Before touching the lens it is advised to clean the surface of the lens by blowing clean air over it. This to avoid that little particles make scratches on the lens.

Because the material of the lens is synthetic and coated with a special anti-reflectivity layer, cleaning must be done with a non-aggressive cleaning fluid. It is advised to use "Cleaning Solvent B4-No2", available with codenumber 4822 389 10026.

The actuator is a very precise mechanical component and may not be damaged in order to guarantee its full function. Clean the lens gently (don't press too hard) with a soft and clean cotton bud moistened with the special lens cleaner.

The direction of cleaning must be in the way as indicated in the picture below.

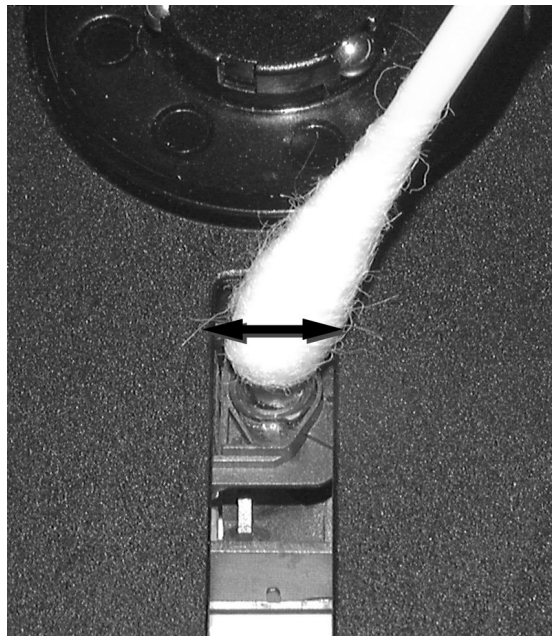

5

EYE-PATTERN SIGNAL – JITTER MEASUREMENT

Measure the signal on the input of the Signal processor using an **analog** oscilloscope. Please find the exact measuring point in your Service Manual.

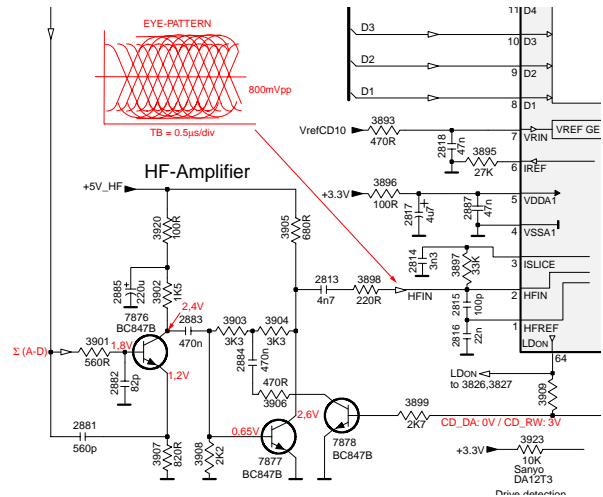

See below examples of the signal. Amplitude should read at least 700mVpp using SBC444A.

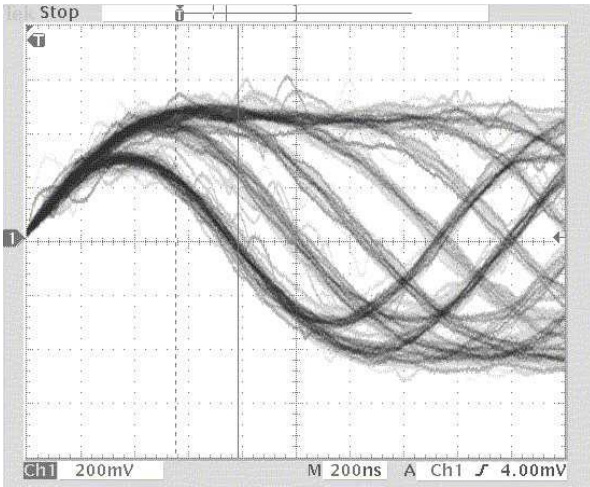

good

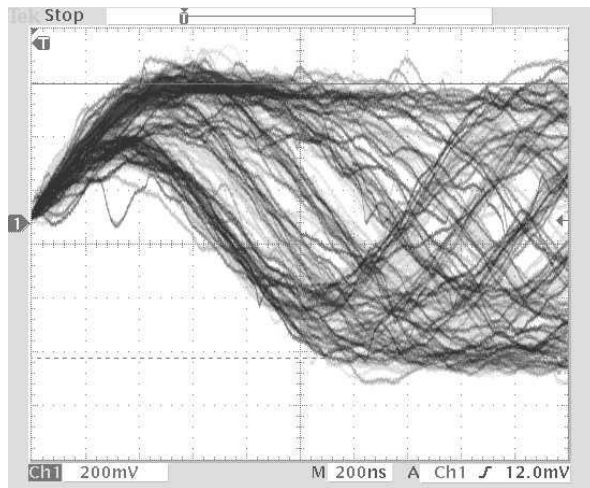

bad

If the oscilloscope shows a signal like the 'bad' one, and/or the amplitude decreases within 1 minute - the CD drive has to be replaced.

6

CD DRIVE – LASER CURRENT MEASUREMENT

The laser current can be measured as a voltage drop on a resistor. The resistor is marked in every Service Manual. The value depends on the type of CD drive.

	typical value	most probably defect
VAMxxxx	: 150-230mV	≥350mV
MCDxx	: 170-230mV	≥300mV
DA1x	: 210-250mV	≥350mV
DA2x	: 175-200mV	≥250mV

Use SBC444A (CD-DA) for measurement.

Laser power control

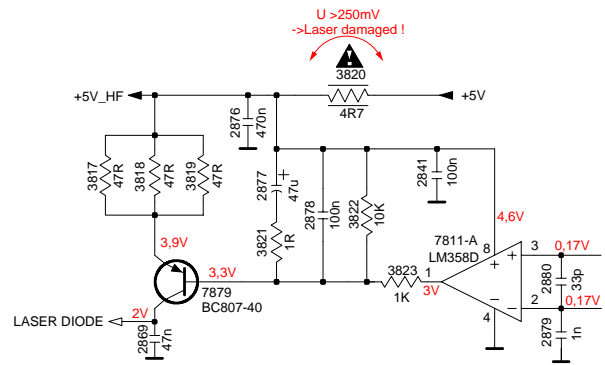

7

CD DRIVE – OFFSET MEASUREMENT

The photodiodes of the CD-drive may have an offset. These offsets have to be compensated by the signal processor. High offsets can lead to poor playability of some CDs (skipping tracks).

To measure the offset values, start the **Service Test Program** - section "Focus Test" without a CD.

The offsets can be measured with a DC Millivoltmeter directly on the connector (see drawing below). Pin numbering varies from drive to drive.

The values from diode A-D should read 0±10mV. Diodes E and F are less critical.

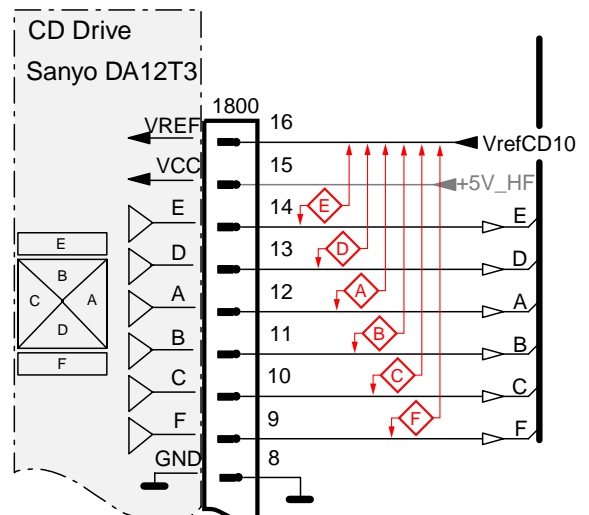

If one of the offsets is higher than ±10mV the CD drive has to be replaced. Otherwise replace the Signal Processor.